

Fig No: KF-315 L/T Full Bore
1/2" ~ 3" DN15 ~ DN80



Features :

- Investment Cast Components
- Split Body design , Blow-out-proof stem design , Bottom entry stem
- Valve design allows 360 degree rotation, positive location is available at 90 degree increments by the valve locking device
- Direct-mounting of actuators to valves design
- For Food , General Chemical and Industrial application
- Carbon steel or special Alloy upon request

Standard Compliance :

- ASME/ANSI B16.34
- Face to Face: Mfg. Std.
- Flange Dimensions: ANSI B16.5 150
- Pressure Test According to API 598

MATERIALS LIST

NO	PART NAME	MATERIAL
1	BODY	ASTM A351 GR.CF8M
4	BALL	ASTM A351 GR.CF8M
5	STEM	S.S.316
9	END CAP	ASTM A351 GR.CF8M
12	SEAT	PTFE.
11	BODY SEAL	PTFE.
14	STEM PACKING	PTFE.
13	THRUST WASHER	PTFE.
15	GLAND BUSH	S.S.304
15	GLAND WASHER	PTFE.
19	HANDLE	S.S.304
21	HANDLE COVER	PLASTIC
22	STEM NUT	S.S.304
23	STEM WASHER	S.S.304
24	HANDLE NUT	S.S.304
28	LOCKING PAD	S.S.304
29	BELLEVILLE WASHER	S.S.301
30	TAB WASHER	S.S.304
31	O-RING	VITON
35	BOLT	S.S.304

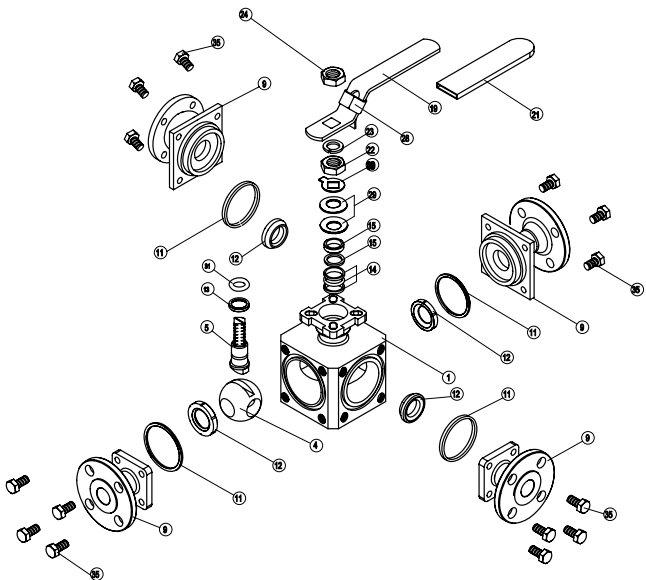
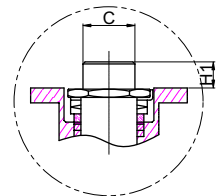
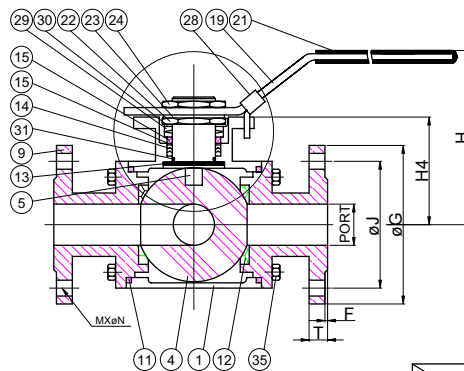
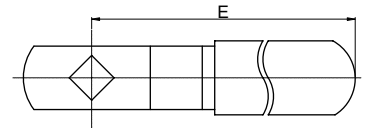
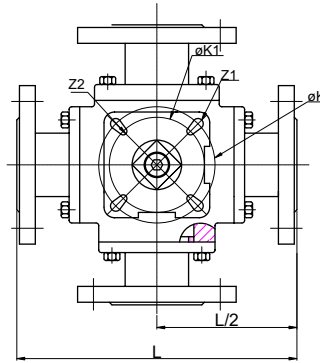

TYPE	1	2	3	4
PORT				
L	1/3 2	1/3 2	1/3 2	1/3 2
T	1/3 2	1/3 2	1/3 2	1/3 2

DIMENSIONS

unit:mm

SIZE	PORT	L	E	H	H1	H4	C	øG	øJ	M	øN	T	F	øK	øK1	Z1	Z2
1/2"	16.0	147.0	133.0	89.0	7.5	50.0	9.0	95.0	65.0	4	14.0	16.0	2.0	42.0	36.0	6.0	6.0
3/4"	20.0	155.0	178.5	98.0	9.5	59.5	11.0	105.0	75.0	4	14.0	18.0	2.0	50.0	42.0	7.1	6.0
1"	25.0	170.0	178.5	102.0	11.0	63.5	11.0	115.0	85.0	4	14.0	18.0	2.0	50.0	42.0	7.1	6.0
1 1/4"	32.0	195.0	230.0	118.5	15.2	79.5	14.0	140.0	100.0	4	18.0	18.0	2.0	70.0	50.0	9.2	7.1
1 1/2"	38.0	240.0	230.0	127.0	14.3	88.0	14.0	150.0	110.0	4	18.0	18.0	2.0	70.0	50.0	9.2	7.1
2"	50.0	261.0	280.0	139.0	17.8	105.0	17.0	165.0	125.0	4	18.0	20.0	2.0	102.0	70.0	11.4	9.2
2 1/2"	65.0	270.0	250.0	117.3	41.5	165.7	17.0	185.0	145.0	4	18.0	18.0	2.0	102.0	70.0	11.0	9.0
3"	80.0	292.2	250.0	128.0	41.5	170.0	17.0	200.0	160.0	8	18.0	20.0	2.0	102.0	70.0	11.0	9.0