

Fig No. MD-22J-150

1-1/2" - 10" (DN40- DN250)



Feature :

- Investment Casting Component
- ISO 5211 mounting flange
- Blow-out-proof stem, Anti-Static Design
- For General Chemical and Industrial application
- Cast Bosses For Bleed / Drain Port.

Standard Compliance:

- Design : B16.34
- Face to face : MFG Standard
- Flange dimension : ANSI Class 150 RF
- Body Material : CF8M
- Pressure testing : EN 12266-1/ API 598

Specifications :

- End connection : Flange RF
- Working pressure : 275 psi (CWP)
- Temperature : -20 ~220°C

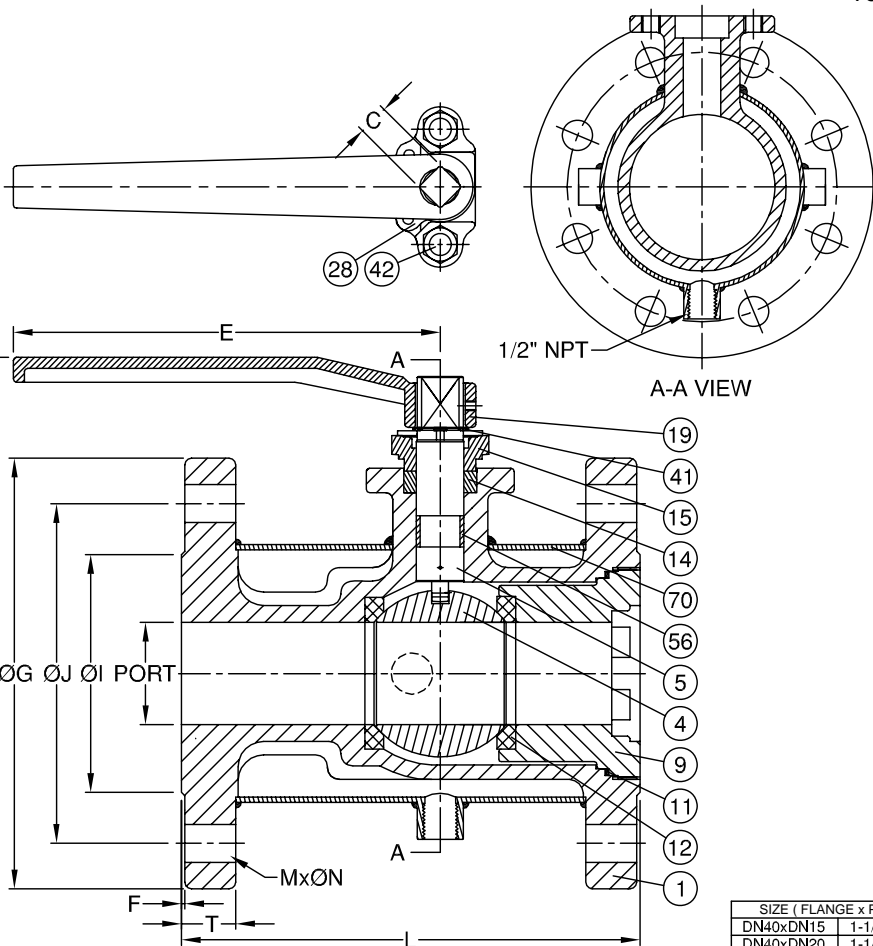

MATERIALS LIST

NO.	PART NAME	MATERIAL
1	BODY	ASTM A351 Gr.CF8M
4	BALL	ASTM A351 Gr.CF8M
5	STEM	SS316
9	INSERT CAP	ASTM A351 Gr.CF8M
11	BODY SEAL	50%PTFE.+50%S.S.
12	SEAT	50%PTFE.+50%S.S.
14	STEM PACKING	50%PTFE.+50%S.S.
15	GLAND	ASTM A351 Gr.CF8M
19	HANDLE	FCD45
28	STOP PLATE	SS304
41	SNAP RING	SS304
42	GLAND BOLT	SS304
56	BEARING	50%PTFE.+50%S.S.
70	JACKET	SS304

FLANGE DIMENSION: ASME B16.5

DIMENSIONS

SIZE (FLANGE x PORT)	PORT	L	E	H	C	OG	OJ	OI	T	F	M	ON	
DN40xDN15	1-1/2" x 1/2"	15	120	150	127	12	127	98.5	73	14.3	1.6	4	16
DN40xDN20	1-1/2" x 3/4"	20	120	150	133	12	127	98.5	73	14.3	1.6	4	16
DN50xDN25	2" x 1"	25	130	150	137	12	152	120.5	92	15.8	1.6	4	19
DN65xDN40	2-1/2" x 1-1/2"	40	165	200	155	17	178	139.5	105	17.5	1.6	4	19
DN80xDN50	3" x 2"	50	180	200	177	17	190	152.5	127	19.1	1.6	4	19
DN100xDN65	4" x 2-1/2"	65	190	300	184	21	229	190.5	157	23.9	1.6	8	19
DN125xDN80	5" x 3"	80	200	300	184	21	254	216.0	186	23.9	1.6	8	22
DN150xDN100	6" x 4"	100	230	300	235	21	279	241.5	216	25.4	1.6	8	22
DN250 x DN200	10" x 8"	200	450	515	340	32	406	362.0	324	30.2	1.6	12	25