

Fig No. MD -28 Full Bore
1/2" ~ 6" DN15 ~ DN150



Feature :

- Investment Casting Component
- ISO 5211 Direct Mounting type
- Blow-out-proof stem, Anti-Static Design
- For General Chemical and Industrial application
- Carbon steel or Super Alloy upon request

Standard Compliance:

- Body wall thickness : EN 12516-1/2
- Face to Face : EN 3202 F4/F5
- Flange Dimension : DIN 2501 PN16
- Finish : 125-250 AARH
- Body Material : EN 10213-4
- Pressure testing : EN12266

Standard Compliance:

- End connection : Flange RF
- Working pressure : 14.6 bar (RT)
- Temperature : -20 ~ 180°C

Option :

- API 607 Fire safe design

MATERIALS LIST

NO.	PART NAME	MATERIAL
1	BODY	1.4408/EN1503-1
4	BALL	ASTM A351 Gr.CF8M
5	STEM	SS316
9	END CAP	1.4408/EN1503-1
11	BODY SEAL	PTFE.
12	SEAT	RTFE.
13	THRUST WASHER	PTFE.
14	STEM PACKING	PTFE.
15	GLAND	SS304
19	HANDLE	SS304
21	HANDLE COVER	PLASTIC
22	STEM NUT	SS304
23	HANDLE WASHER	SS304
24	HANDLE NUT	SS304
28	LOCKING PAD	SS304
29	BELLEVILLE WASHER	SS304
30	TAB WASHER	SS304
31	STEM O-RING	VITON
32	PACKING FOLLOWER	RTFE.
33	STOP PIN	SS304
35	BODY STUD	ASTM A193 Gr.B8
37	BOLT NUT	ASTM A194 Gr.8

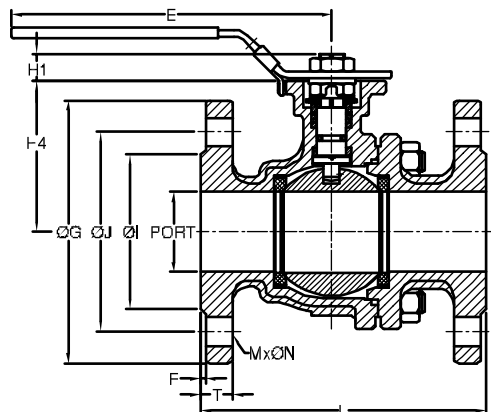
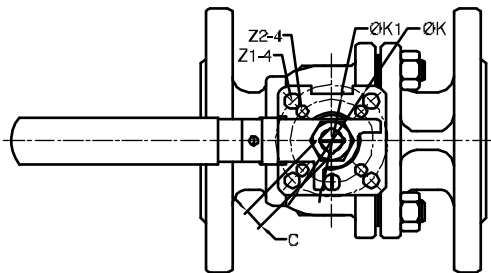
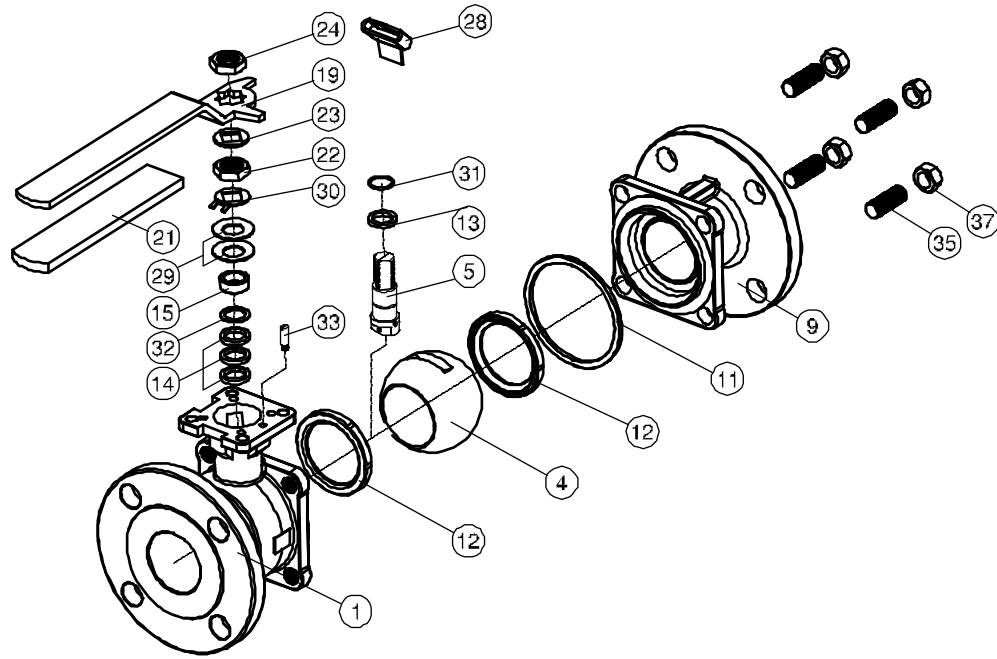

DIMENSIONS

unit:mm

SIZE	PORT	L	E	H1	H4	C	OG	OJ	OI	T	F	M	ØN	ØK	ØK1	Z1	Z2	
DN15	1/2"	15.0	115.0	112.0	8.5	48.0	9.0	95.0	65.0	45.0	16.0	2.0	4	14.0	50.0	36.0	7.0	6.0
DN20	3/4"	20.0	120.0	112.0	8.5	62.0	9.0	105.0	75.0	58.0	18.0	2.0	4	14.0	50.0	36.0	7.0	6.0
DN25	1"	25.0	125.0	138.0	11.4	64.0	9.0	115.0	85.0	68.0	18.0	2.0	4	14.0	50.0	36.0	7.0	6.0
DN32	1-1/4"	32.0	130.0	195.0	11.4	71.0	9.0	140.0	100.0	78.0	18.0	2.0	4	18.0	50.0	36.0	7.0	6.0
DN40	1-1/2"	38.0	140.0	198.0	14.0	76.0	14.0	150.0	110.0	88.0	18.0	2.0	4	18.0	70.0	50.0	9.0	7.0
DN50	2"	50.0	150.0	198.0	13.7	84.5	14.0	165.0	125.0	102.0	20.0	2.0	4	18.0	70.0	50.0	9.0	7.0
DN65	2-1/2"	63.0	170.0	265.0	18.0	106.8	17.0	195.0	145.0	122.0	18.0	2.0	4	18.0	102.0	70.0	11.0	9.0
DN80	3"	76.0	180.0	265.0	18.0	116.0	17.0	200.0	160.0	138.0	20.0	2.0	8	18.0	102.0	70.0	11.0	9.0
DN100	4"	100.0	190.0	325.0	18.0	154.5	17.0	220.0	180.0	158.0	20.0	2.0	8	18.0	102.0	70.0	11.0	9.0

Fig No. MD -28 Full Bore
1/2" ~ 6" DN15 ~ DN150



Feature :

- Investment Casting Component
- ISO 5211 Direct Mounting type
- Blow-out-proof stem, Anti-Static Design
- For General Chemical and Industrial application
- Carbon steel or Super Alloy upon request

Standard Compliance:

- Body wall thickness : EN 12516-1/2
- Face to Face : EN 3202 F4/F5
- Flange Dimension : DIN 2501 PN16
- Finish : 125-250 AARH
- Body Material : EN 10213-4
- Pressure testing : EN12266

Standard Compliance:

- End connection : Flange RF
- Working pressure : 14.6 Bar (RT)
- Temperature : -20 ~ 180° C

Option :

- API 607 Fire safe design

MATERIALS LIST

NO.	PART NAME	MATERIAL
1	BODY	1.4408/EN1503-1
4	BALL	ASTM A351 Gr.CF8M
5	STEM	SS316
9	END CAP	1.4408/EN1503-1
11	BODY SEAL	PTFE.
12	SEAT	RTFE.
13	THRUST WASHER	PTFE.
14	STEM PACKING	PTFE.
15	GLAND	SS304
19	HANDLE	FCD45
20	SET SCREW	SS304
22	STEM NUT	SS304
23	HANDLE WASHER	SS304
24	HANDLE NUT	SS304
28	TRIANGLE STOPPER	SS304
29	BELLEVILLE WASHER	SS304
30	TAB WASHER	SS304
31	STEM O-RING	VITON
32	PACKING FOLLOWER	RTFE.
33	STOP PIN	SS304
35	BODY STUD	ASTM A193 Gr.B8
37	BOLT NUT	ASTM A194 Gr.8

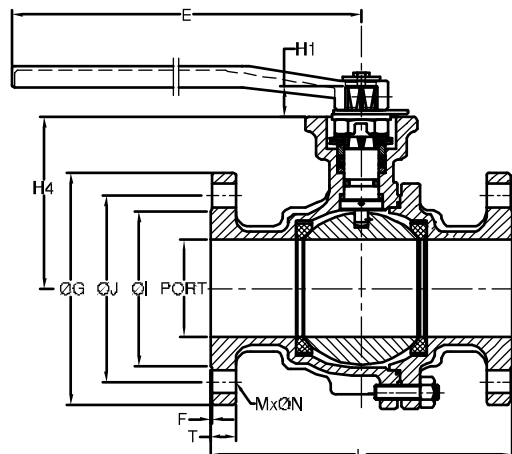
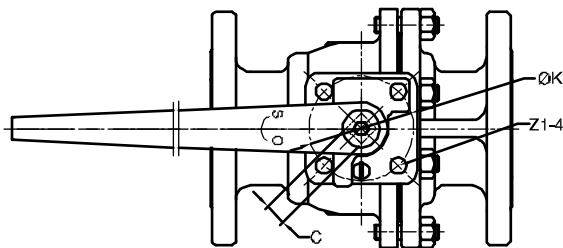
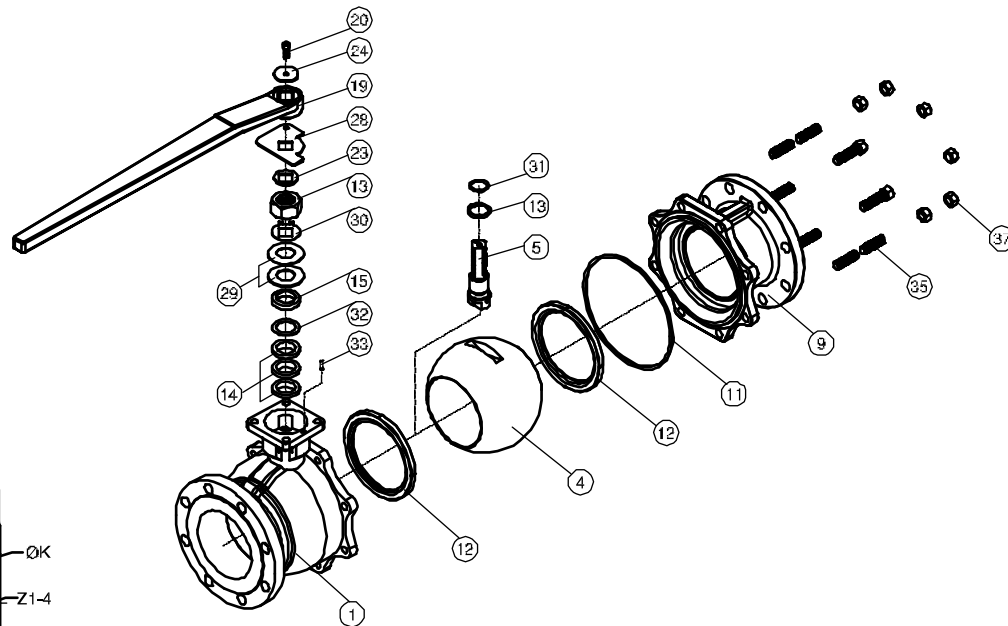

DIMENSIONS

unit:mm

SIZE	PORT	L	E	H1	H4	C	ØG	ØJ	ØI	T	F	M	ØN	ØK1	Z1-4	
DN125	5"	125.0	325.0	750.0	30.0	194.0	27.0	250.0	210.0	188.0	22.0	2.0	8	18.0	125.0	14.0
DN150	6"	150.0	350.0	750.0	30.0	213.0	27.0	285.0	240.0	212.0	22.0	2.0	8	22.0	125.0	14.0