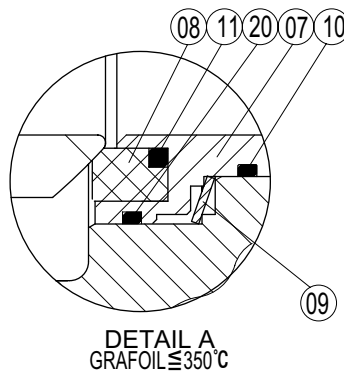
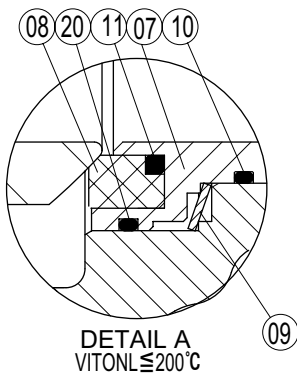
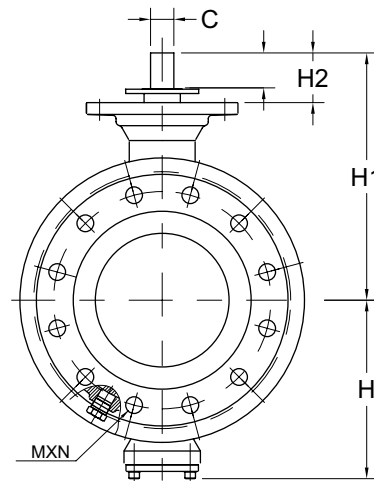
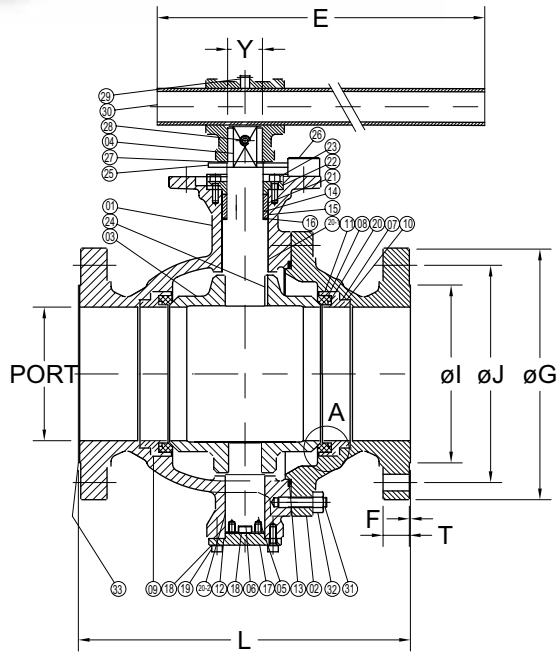

**Fig No: MD-52QT-150 Full Bore**  
**4" ~ 8" DN100 ~ DN200**



Split body design , allows the use of advanced spiral - wound gaskets.  
 Blowout - proof stem, trunnion mounted type.  
 All valves with graphite packing and backup seal are inherently fire safe  
 Ball and seats lapped for optimum performance and tight shutoff  
 Wall thickness : AMSE/ANSI B16.34 CLASS 150 full port only  
 Flanged dimensions : ANSI B16.5 Class 150  
 Face to Face : ANSI B16.10 Class 150 RF  
 Pressure-Temperature Rating : ASME B16.34  
 Tightness rates :  $\Delta P$  : ASME / FCI 70-2 Class IV  
 Temperature limitation  $\leq 350^{\circ}c$  for grafoil seal kits  
 $\leq 200^{\circ}c$  for viton seal kits



**DIMENSIONS**

SIZE	PORT	L	E	H	H1	H2	H3	C	Y	øG	øJ	øI	T	F	M	øN	W/G TYPE
4"	100.0	228.6	500.0	170.0	200.0	25.0	37.0	23.0	ø35	228.6	190.5	157.2	23.8	1.6	8	19.1	WG0
6"	150.0	393.7	800.0	210.0	251.0	40.0	52.0	26.0	ø40	279.4	241.3	215.9	25.4	1.6	8	22.2	WG1
8"	200.0	457.2	1100.0	275.0	301.0	40.0	60.0	35.0	ø53	342.9	298.5	269.8	28.6	1.6	8	22.2	WG1

**MATERIALS LIST**

NO.	PARTS NAME	MATERIALS		
1	BODY	ASTM A216-WCB	ASTM A351-CF8	ASTM A351-CF8M
2	END CAP	ASTM A216-WCB	ASTM A351-CF8	ASTM A351-CF8M
3	BALL	ASTM A351-CF8+HCr		ASTM A351-CF8M+HCr
4	STEM	ASTM A276-410	ASTM A276-304	ASTM A276-316
5	LONER STEM	ASTM A276-410	ASTM A276-304	ASTM A276-316
6	BOTTOR BEARING	P-H3(PTFE+MOS2)		
7	SEAT RETAINER	ASTM A105+Cr,PLT	ASTM A182-F304	ASTM A182-F316
8	SEAT	ASTM A276-304+STL#6	ASTM A276-304+STL#6	ASTM A276-304+STL#6
9	SPRING	ASTM A240-301		
10	O RING	Viton ( or Grafoil)		
11	O RING	Viton ( or Grafoil)		
12	O RING	Viton ( or Grafoil)		
13	BODY SEAL	Viton ( or Grafoil)		
14	O RING	Viton ( or Grafoil)		
15	O RING	Viton ( or Grafoil)		
16	THRUST WASHER	P-H3(PTFE+MOS2)		
17	BOTTOM COVER	ASTM A105	ASTM A240-304	ASTM A240-316
18	SPRING WASHER	ASTM A510-1060	S.S	S.S
19	HX. SOCKET CAP SCREW	ASTM A193-B7	ASTM A193-8	ASTM A193-8
20	SEAT GASKET	P-H3(PTFE+MOS2)		
20-1	STEM BUSHING	P-H3(PTFE+MOS2)		
20-2	STEM BEARING	P-H3(PTFE+MOS2)		
21	GLAND	ASTM A276-304		ASTM A276-316
22	GLAND FLANGE	ASTM A216WCB	ASTM A351-CF8	ASTM A351-CF8M
23	GLAND BOLT	ASTM A193-B7	ASTM A193-B8	ASTM A193-B8
24	KEY	ASTM A276-316		
25	STOPPER	ASTM A176-304		
26	HX. SOCKET CAP SCREW	ASTM A193-B8		
27	C-RING	ASTM A516-1060		
28	HANDLE	ASTM A536/A216-WCB		
29	SET SCREW	ASTM A193-B6		
30	STEEL PIPE	ASTM A53		
31	STUD	ASTM A193-B7	ASTM A193-B8	ASTM A193-B8
32	BOLT NUT	ASTM A194-2H	ASTM A194-8	ASTM A194-8
33	END COVER	WOOD / P.E.		