

Fig No:SF-300 2"~ 36" DN50~DN900

Features:

- Swing type design
- Bolted Bonnet
- Body and Bonnet joint accurately machined, Full enclosed gasket
- Disc-Robust one-piece construction to withstand the severe shock of check valve service
- Disc assembly-All parts are accessible from top for easy servicing
- Seat face stellited, ground and lapped to a mirror finish

Sample Castings:

Before castings are released for production, the Modentic NDE inspector level, evaluates and approves the submitted x-ray films (100% coverage) as per ASME B16.34 acceptance standard. Improves the internal integrity of castings (RT level 2 or better) at pattern approval.

Standard compliance:

- Valve design according to API 600, BS 1868
- Shell wall Thickness according to API 600, BS 1868 class 300
- Pressure-temperature rating according to ASME/ANSI B16.34
- Material according to ASTM
- Face to Face according to ASME/ANSI B16.10 class 300 RF
- End to end according to ASME/ANSI B16.10 class 300 BW
- Flanged dimension according to ASME/ANSI B16.5 class 300 RF, Finish 125-250 AARH
- Butt weld dimension according to ASME/ANSI B16.25
- Pressure testing according to API 598

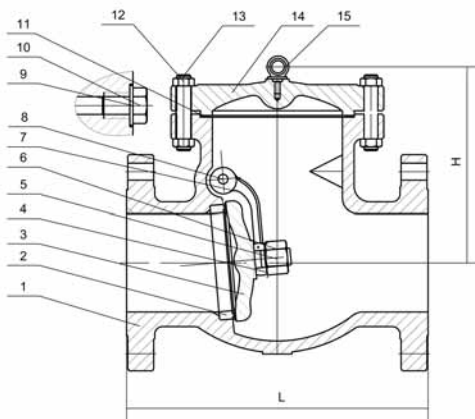

DIMENSIONS unit:mm

SIZE	L	H
2"	267	176
2.5"	292	205
3"	318	216
4"	356	259
6"	445	295
8"	533	330
10"	622	420
12"	711	480
14"	838	535
16"	864	585
18"	978	615
20"	1016	685
22"	1118	730
24"	1346	785
26"	1346	810
28"	1499	835
30"	1594	865
32"	1594	902
36"	2083	920

MATERIAL LIST

NO	Part Name	Material
1	Body	ASTM A216 GR.WCB
2	Seat Ring	ASTM A105+1HF Faced
3	Disc	ASTM A216 GR.WCB+13%Cr Faced
4	Disc Washer	STAINLESS STEEL
5	Pin	ASTM A276 Type 410
6	Disc Nut	ASTM A276 Type 410
7	Hinge	ASTM A216 GR.WCB
8	Hinge Pin	ASTM A276 Type 410
9	Spring Washer	CARBON STEEL
10	Plug	A276-410
11	Gasket	304-Graphite, Spiral Wound
12	Cover Bolt	ASTM A193 GR.B7
13	Cover Bolt Nut	ASTM A194 GR.2H
14	Cover	ASTM A216 GR.WCB
15	Lifting Ring	CARBON STEEL

Other Materials Also Available On Requested