

Fig no. WA-002S Full Bore
1/4" ~ 4" DN8 ~ 100



Feature :

- Investment casting component
- Horizontal or Vertical Installation
- Low pressure drop
- For General chemical and industrial application

Standard Compliance :

- Body wall thickness : EN 12516-1/2/3
- Socket weld : B16.11
- Face to Face : MFG's standard
- Body material : EN10213-4
- Pressure testing : EN 12266

Specification:

- End connection :Socket weld end
- Working pressure : 40 bar (CWP)
- Temperatue : -20 ~ 180°C

MATERIALS LIST

NO.	PART NAME	MATERIAL
1	BODY	1.4408 / EN1503-1
4	DISC	1.4408 / EN1503-1
5	SPRING	SS316
9	END CAP	1.4408 / EN1503-1
11	BODY SEAL	PTFE.
35	BODY BOLT	SS304
36	BOLT WASHER	SS304
37	BOLT NUT	SS304
43	HOLDER	SS316

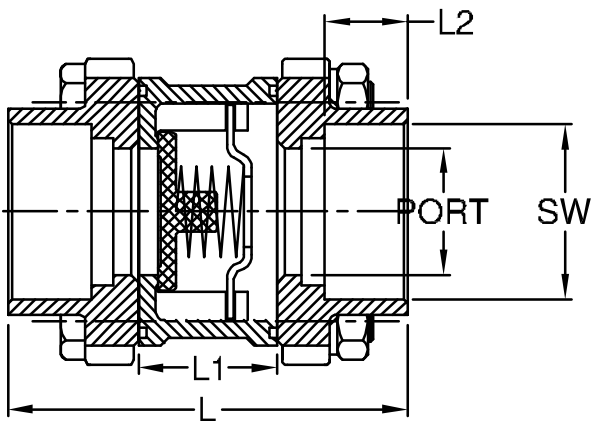
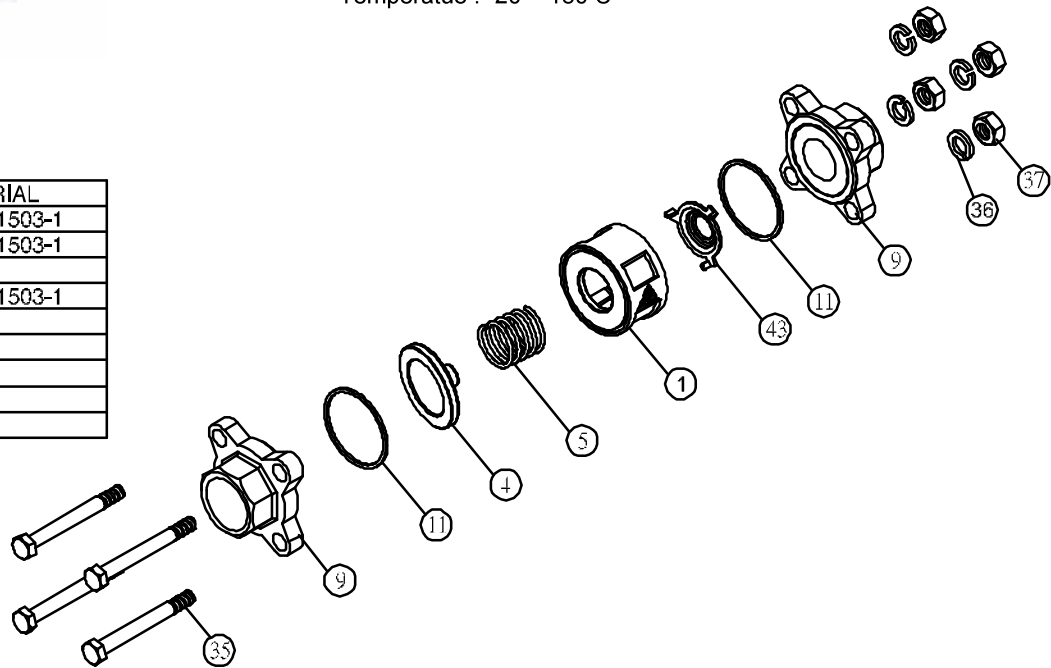

DIMENSIONS

SIZE	PORT	L	L1	L2	SW
DN8	1/4"	12.0	53.0	14.0	14.0
DN10	3/8"	12.0	53.0	14.0	17.5
DN15	1/2"	15.0	67.0	18.0	22.0
DN20	3/4"	20.0	69.0	22.0	27.5
DN25	1"	25.0	79.0	27.5	34.5
DN32	1-1/4"	32.0	92.0	32.0	43.3
DN40	1-1/2"	40.0	101.0	37.0	49.2
DN50	2"	50.0	115.0	47.0	61.2
DN65	2-1/2"	65.0	145.0	47.0	77.0
DN80	3"	80.0	154.0	55.0	89.9
DN100	4"	100.0	180.0	70.0	115.0

Opening pressure STD in Mbar
 Prasion apertura Standard in Mbar

DN 25	25	21	23	DN 40	29	21	25	DN 65	31	21	25	DN 100	33	21	27
▲	▼	▶	▲	▼	▶	▲	▼	▶	▲	▼	▶	▲	▼	▶	
DN 32	27	21	24	DN 50	29	21	25	DN 80	32	21	26				
▲	▼	▶	▲	▼	▶	▲	▼	▶							