

Fig No:MD-938EB BPE Dimension

1/2"~4" DN15~DN100



Features :

- Extended tube OD for automatic orbital welding
- ID Internal surface finish:
- Mechanical polished to Ra 20 μ -in;
- Mechanical & Electropolished to Ra 15 μ -in

Specifications :

- Materials : Stainless steel F316L, Hasteloy C22, AL-6XN
- Seats : TFM 1600
- Applications :
- Pharmaceutical, Biotech, Food & Beverage, Cosmetics
- Temperature rating : -57°C ~ 180°C (-70°F ~ 356°F)
- Clamp end for option

Standards Compliance :

- ASME / BPE
- FDA 21CFR 177 / USP 23 Class VI
- API 598

MATERIALS LIST

NO.	PART NAME	MATERIAL		QTY
1	BODY	ASTM A182 GR.F316L	S.S.316	1
4	BALL	ASTM A182 GR.F316L	S.S.316	1
5	STEM	S.S.316		1
9	CAP	ASTM A182 GR.F316L	S.S.316	2
11	BODY SEALS	TFM1600		2/1 SETS
12	BALL SEATS	TFM1600		2/1 SETS
13	THRUST WASHER	TFM1600		1
14	STEM PACKING	TFM1600		1 SETS
15	GLAND BUSH	S.S.304		1
19	HANDLE	S.S.304		1
21	HANDLE SLEEVE	VINYL GRIP	PLASTIC	1
24	HANDLE NUT	S.S.304		2
29	BALLEVILLE WASAER	SUS304-CSP	S.S.310	2
30	CROWN WASHER	S.S.304		1
31	O-RING	VITON		1
32	PACKING FOLLOWER	TFM1600	RTFE.	1
33	LEVER STOP	S.S.304		1
35	BODY BOLT	A2-70	S.S.304	8
36	BOLT WASHER	S.S.304		8

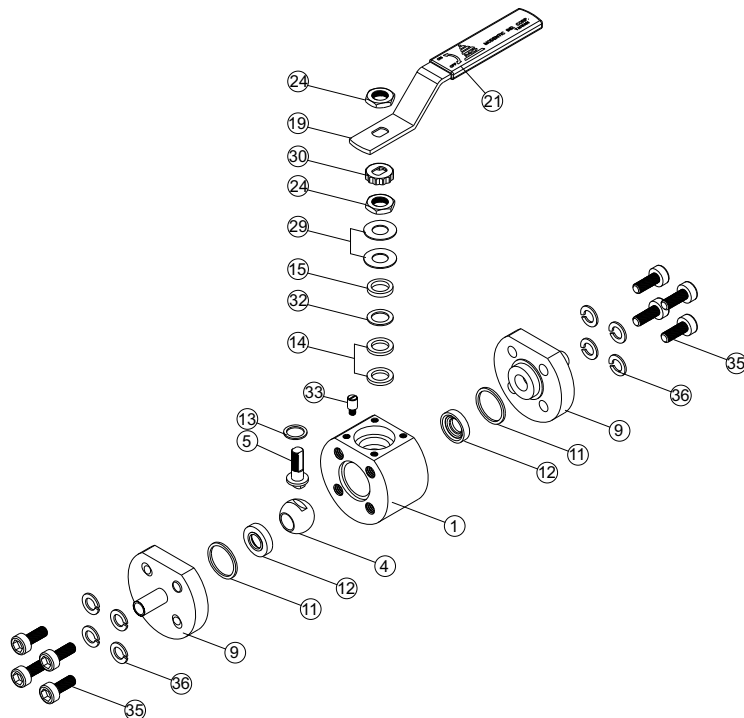
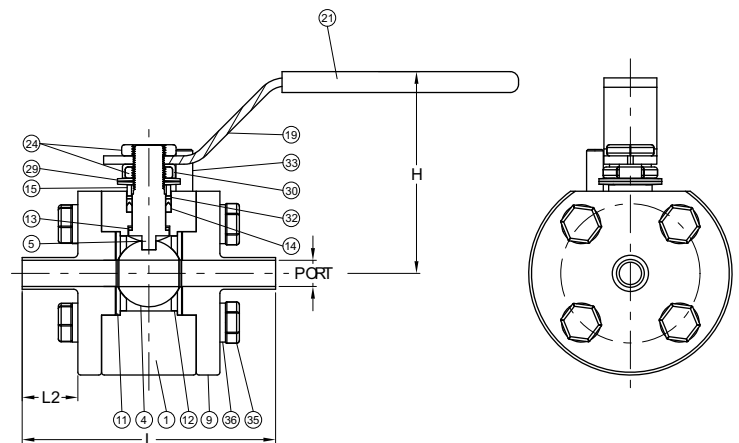
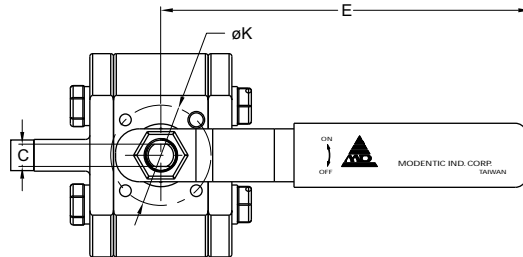

DIMENSIONS

unit:inch

SIZE	PORT	L	L2	E	H	C	øK	Z
1/4"	0.181	4.862	1.575	5.551	2.909	0.354	1.417	M5
3/8"	0.307	4.862	1.575	5.551	2.909	0.354	1.417	M5
1/2"	0.370	4.862	1.575	5.551	2.909	0.354	1.417	M5
3/4"	0.622	5.039	1.575	5.551	3.145	0.354	1.417	M5
1"	0.870	5.315	1.575	5.551	3.185	0.354	1.417	M5
1-1/2"	1.370	6.102	1.575	1.575	3.940	0.433	1.968	M6
2"	1.870	6.634	1.575	1.575	4.255	0.433	1.968	M6
2-1/2"	2.370	7.520	1.575	1.575	5.566	0.551	2.755	M8
3"	2.870	9.055	1.969	1.969	6.204	0.551	2.755	M10
							4.015	
4"	3.838	9.980	1.969	1.969	7.011	0.669	2.755	M10
							4.015	